



手把型錄 技術手冊

DARE

目錄

一體把

- 01 V:C1
- 03 G:C1
- 05 AERO1v
- 07 AERO1v R68
- 09 AERO1

輕量把

- 11 REMO
- 13 ERGO ACE

外擴把

- 15 G:H1
- 17 ERGO 14

空力把

- 19 VETOX ACE
- 21 AEROMAX





V:C1

V:C1 幾何表

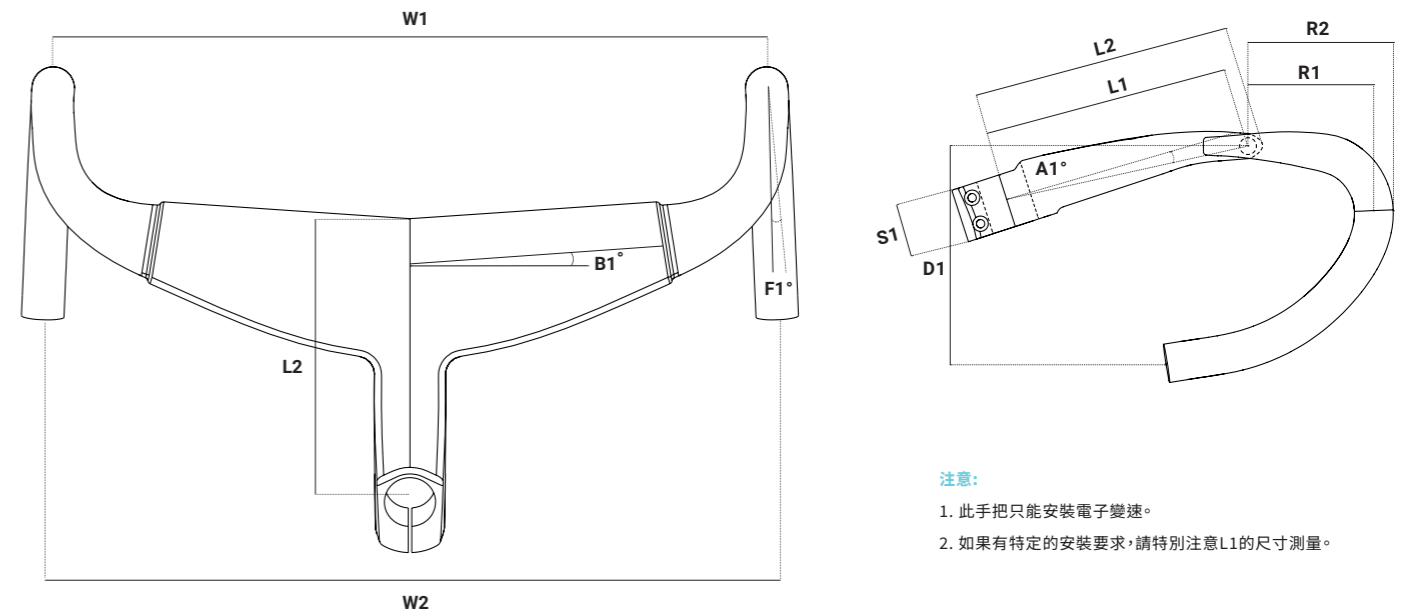

- 注意:**
1. 此手把只能安裝電子變速。
 2. 如果有特定的安裝要求,請特別注意L1的尺寸測量。

關於 V:C1

類型	一體空力把
材質	碳纖維
尺寸	34 · 36 · 38 · 40 · 42
重量	350±10g (105-400mm)
相容型號	VA-AFO
走線	內走線 (僅適用於無線電子變速)
碼錶座	有



尺寸 (mm)	34	36	38	40	42
W1 Hood-to-hood	340	360	380	400	400
W2 Drop-to-drop	352	372	392	412	432
R1 Reach	80	80	80	80	80
R2 Reach	92	92	92	92	92
D1 Drop	134	134	134	134	134
F1 Drop flare	3	3	3	3	3
B1 Backsweep	-4	-4	-4	-4	-4
A1 Angle	-6	-6	-6	-6	-6
S1 Stack	33	33	33	33	33
L1 Stem length*	90 · 100 · 110 · 120	90 · 100 · 110 · 120 130 · 140 · 150*	100 · 110 · 120 130 · 140 · 150*	100 · 110 · 120 130 · 140 · 150*	100 · 110 · 120 130 · 140 · 150*
L2 Stem length	106 · 116 · 126 · 136	106 · 116 · 126 136 · 146 · 156 · 166	106 · 126 · 136 146 · 156 · 166	106 · 126 · 136 146 · 156 · 166	106 · 126 · 136 146 · 156 · 166

*L1龍頭長度 = 龍頭束管中心到手把前緣弧度中心,即L2減8mm。

*紅色標示的 L1 龍頭長度為特殊尺寸,確認訂單後預計交期為 12 週。



G:C1

關於 G:C1

類型	一體外擴把
材質	碳纖維
尺寸	40 · 42 · 44 · 46
重量	350±10g (105-400mm)
相容型號	GA · MA-AFO
走線	內走線 (僅適用於電子變速)
碼錶座	有



G:C1 幾何表

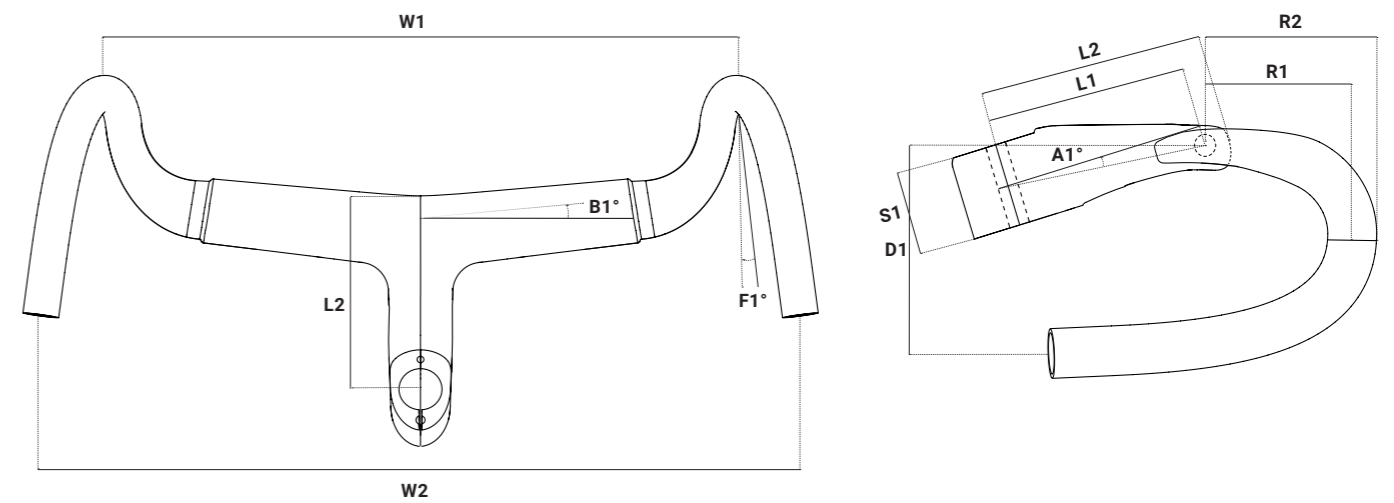

尺寸 (mm)	40	42	44	46
W1 Hood-to-hood	400	420	440	460
W2 Drop-to-drop	486	506	526	546
R1 Reach	70	70	70	70
R2 Reach	88	88	88	88
D1 Drop	100	100	100	100
F1 Drop flare	24	24	24	24
B1 Backsweep	-4	-4	-4	-4
A1 Angle	-6	-6	-6	-6
S1 Stack	40.5	40.5	40.5	40.5
L1 Stem length*	80 · 90 · 105	90 · 105	90 · 105	90 · 105
L2 Stem length	87 · 97 · 112	97 · 112	97 · 112	97 · 112

*L1龍頭長度 = 龍頭束管中心到手把前緣弧度中心, 即L2減7mm。



AERO1v 幾何表

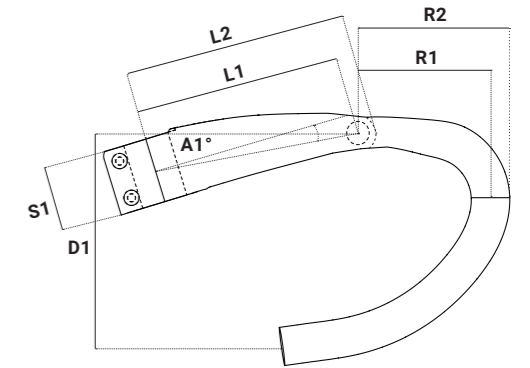
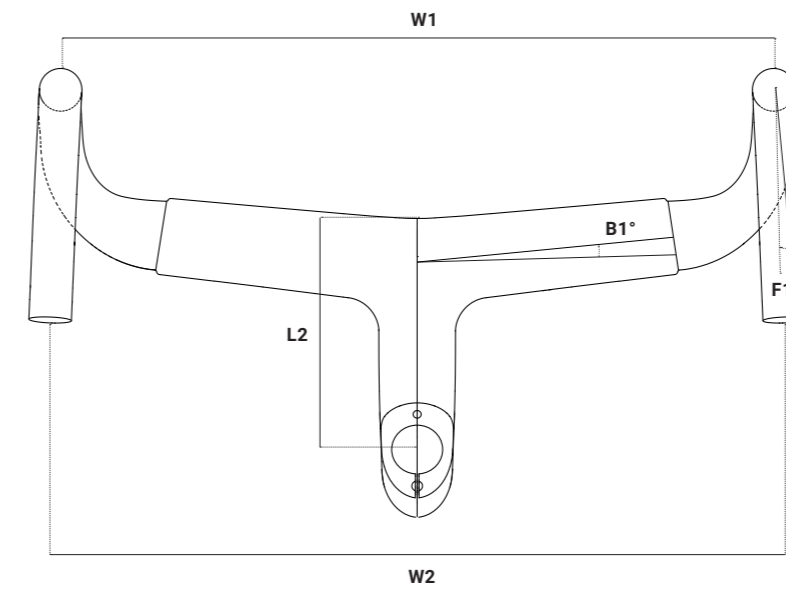

注意:

1. 此手把只能與電子換檔齒輪組件一起安裝。
2. 如果有特定的安裝要求,請特別注意L1的尺寸測量。

關於 AERO1v

類型	一體全能把
材質	碳纖維
尺寸	36 · 38 · 40 · 42
重量	350±10g (105-400mm)
相容型號	MA-AFO · VSRu 2023
走線	內走線 (僅適用於電子變速)
碼錶座	有



配有最新Shimano
上把位衛星變速按鈕
(SW-RS801-T)安裝孔位。

尺寸 (mm)	36	38	40	42
W1 Hood-to-hood	360	380	400	420
W2 Drop-to-drop	372	392	412	432
R1 Reach	80	80	80	80
R2 Reach	92	92	92	92
D1 Drop	134	134	134	134
F1 Drop flare	2	2	2	2
B1 Backsweep	-5	-5	-5	-5
A1 Angle	-6	-6	-6	-6
S1 Stack	41	41	41	41
L1 Stem length*	80 · 90 · 105 · 120	80 · 90 · 105 · 120	90 · 105 · 120 · 130	90 · 105 · 120 · 130
L2 Stem length	87 · 97 · 112 · 127	87 · 97 · 112 · 127	97 · 112 · 127 · 137	97 · 112 · 127 · 137

*L1龍頭長度 = 龍頭束管中心到手把前緣弧度中心,即L2減7mm。



AERO1v R68 幾何表

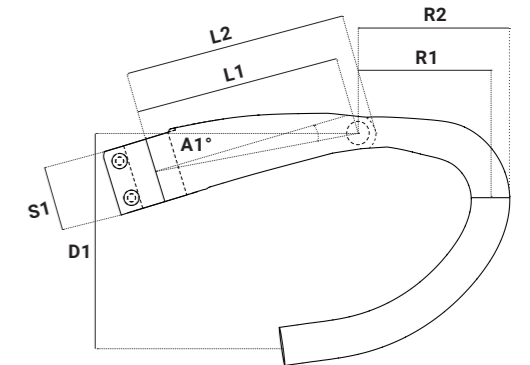
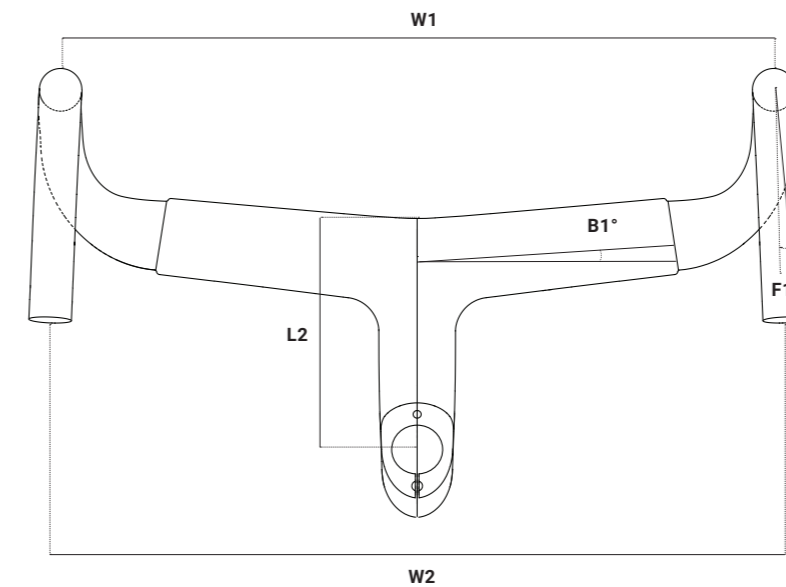

注意:

1. 此手把只能與電子換檔齒輪組件一起安裝。
2. 如果有特定的安裝要求,請特別注意L1的尺寸測量。

關於 AERO1v R68

類型	一體全能把
材質	碳纖維
尺寸	36 · 38
重量	350±10g (105-400mm)
特色	小手友善
相容型號	MA-AFO · VSRu 2023
走線	內走線 (僅適用於電子變速)
碼錶座	有



配有最新Shimano
上把位衛星變速按鈕
(SW-RS801-T)安裝孔位。



尺寸(mm)	36	38
W1 Hood-to-hood	360	380
W2 Drop-to-drop	372	392
R1 Reach	68	68
R2 Reach	79	79
D1 Drop	134	134
F1 Drop flare	2	2
B1 Backsweep	-5	-5
A1 Angle	-6	-6
S1 Stack	41	41
L1 Stem length*	105 · 120 · 130	105 · 120
L2 Stem length	112 · 127 · 137	112 · 127

*L1龍頭長度 = 龍頭束管中心到手把前緣弧度中心,即L2減7mm。



AERO1

AERO1 幾何表

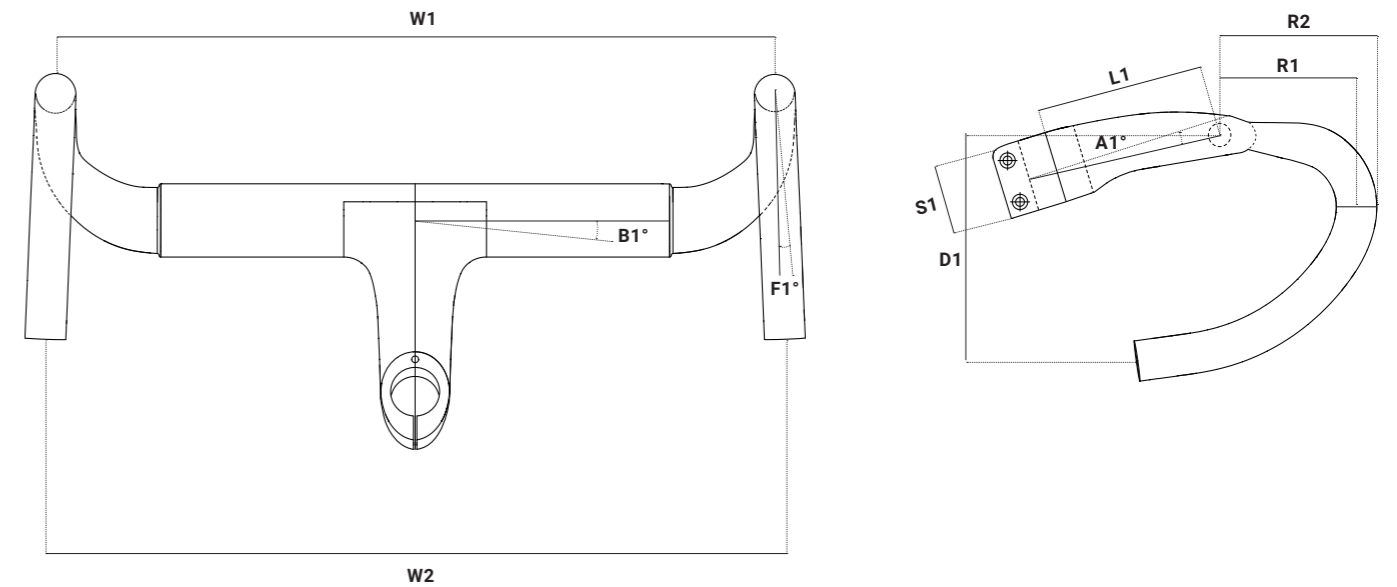

關於 AERO1

類型	一體全能把
材質	碳纖維
尺寸	40 · 42 · 44
重量	375±10g (105-400mm)
相容型號	MA-AFO · MR1s
走線	半內走線
碼錶座	有



尺寸 (mm)	40	42	44
W1 Hood-to-hood	400	420	440
W2 Drop-to-drop	412	432	452
R1 Reach	80	80	80
R2 Reach	91	91	91
D1 Drop	133.8	133.8	133.8
F1 Drop flare	2.4	2.4	2.4
B1 Backsweep	0	0	0
A1 Angle	-7	-7	-7
S1 Stack	43	43	43
L1 Stem length	80 · 90 · 105 · 120	90 · 105 · 120 · 130	90 · 105 · 120 · 130

REMO



關於 REMO

類型	輕量把
材質	碳纖維
尺寸	36 • 38 • 40 • 42 • 44
重量	210±10g
相容型號	MA-AFO • MR1s • GFX
走線	外走線 內走線 (僅適用於電子變速)



配有最新Shimano
上把位衛星變速按鈕
(SW-RS801-T)安裝孔位。

REMO 幾何表

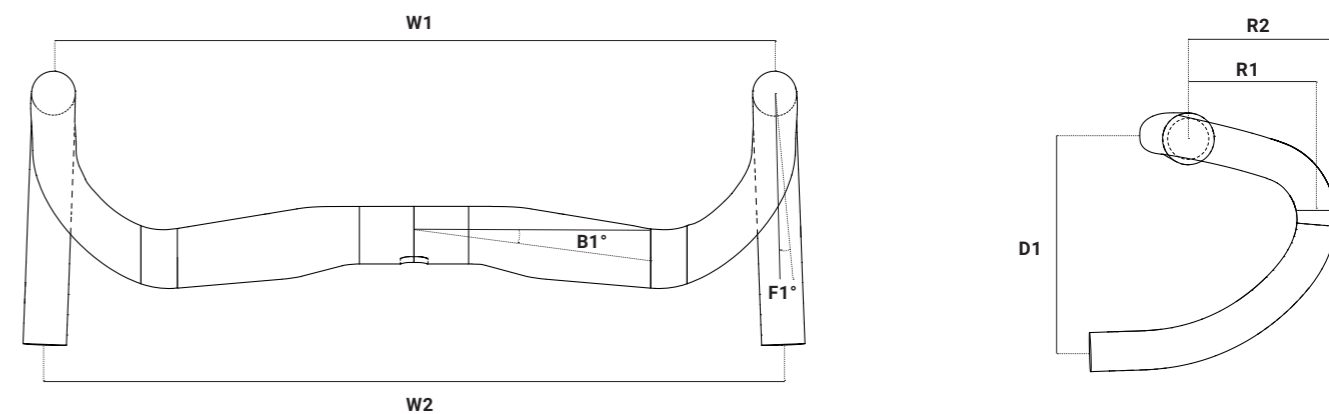

尺寸 (mm)	36	38	40	42	44
W1 Hood-to-hood	360	380	400	420	440
W2 Drop-to-drop	379	386	412	432	452
R1 Reach	76	78	78	78	78
R2 Reach	88	90	90	90	90
D1 Drop	118	130	130	130	130
F1 Drop flare	5	2.2	2.2	2.2	2.2
B1 Backsweep	-9.5	-7.5	-7.5	-7.5	-7.5



ERGO ACE



關於 ERGO ACE

- 類型 輕量競速把
- 材質 碳纖維
- 尺寸 36 • 38 • 40 • 42 • 44
- 重量 205±10g
- 相容型號 MA-AFO • MR1s
- 走線 外走線
內走線 (僅適用於電子變速)



ERGO ACE 幾何表

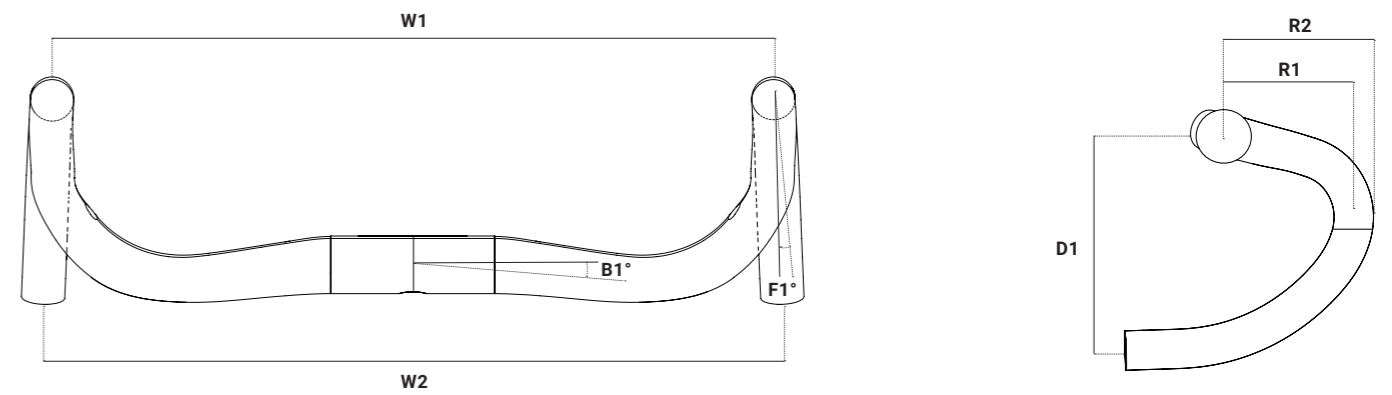

尺寸 (mm)	36	38	40	42	44
W1 Hood-to-hood	360	380	400	420	440
W2 Drop-to-drop	379	386	406	426	446
R1 Reach	76	78	78	78	78
R2 Reach	88	90	90	90	90
D1 Drop	118	130	130	130	130
F1 Drop flare	5	2	2	2	2
B1 Backsweep	-4	-4	-4	-4	-4



關於 G:H1

類型	外擴把
材質	碳纖維
尺寸	40 · 42 · 44 · 46
重量	225±10g
相容型號	GA · GFX · MA-AFO · MR1s
走線	內走線 (僅適用於電子變速)



G:H1 幾何表

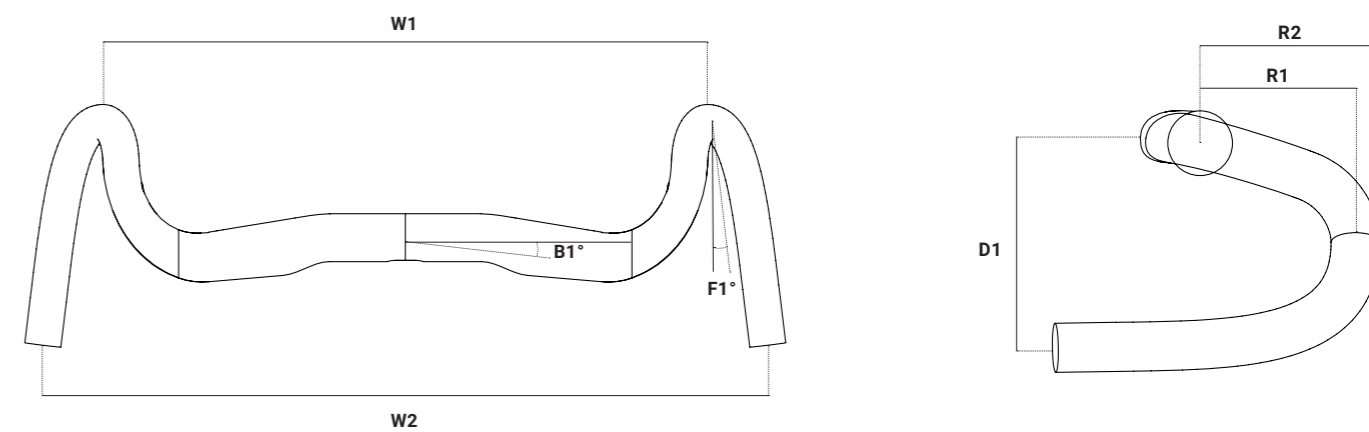

尺寸 (mm)	40	42	44	46
W1 Hood-to-hood	400	420	440	460
W2 Drop-to-drop	480	500	520	540
R1 Reach	76	76	76	76
R2 Reach	90	90	90	90
D1 Drop	100	100	100	100
F1 Drop flare	24	24	24	24
B1 Backsweep	-5	-5	-5	-5



ERGO 14



關於 ERGO 14

類型	外擴把
材質	碳纖維
尺寸	38 · 40 · 42 · 44
重量	205±10g
相容型號	GFX · MA-AFO · MR1s
走線	外走線



ERGO 14 幾何表

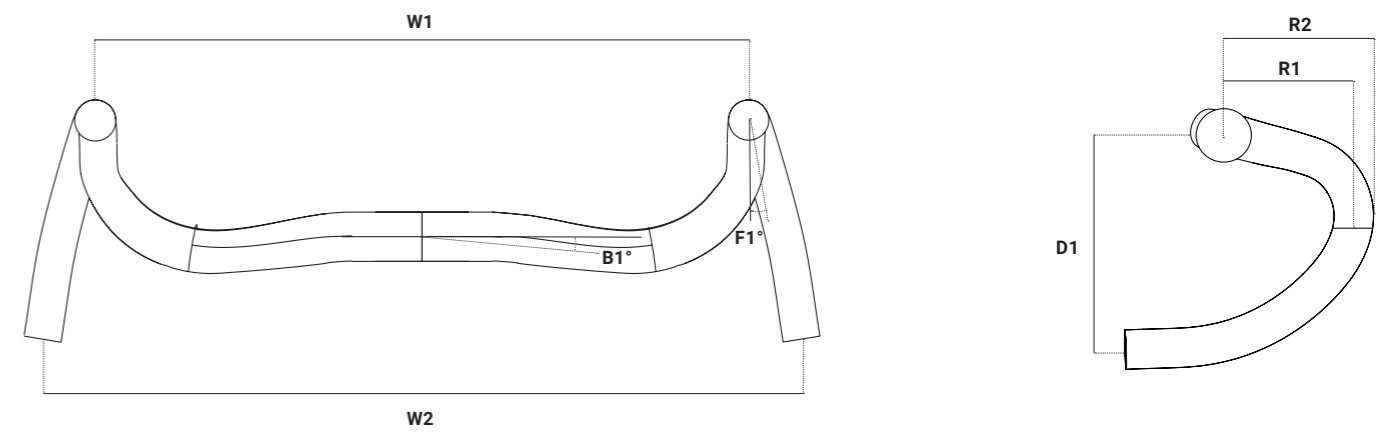

尺寸 (mm)	38	40	42	44
W1 Hood-to-hood	380	400	420	440
W2 Drop-to-drop	447	467	487	507
R1 Reach	78	78	78	78
R2 Reach	90	90	90	90
D1 Drop	130	130	130	130
F1 Drop flare	14	14	14	14
B1 Backsweep	-3	-3	-3	-3



VETOX ACE

關於 VETOX ACE

- 類型 空力把
- 材質 碳纖維
- 尺寸 38 · 40 · 42 · 44
- 重量 260±10g
- 相容型號 VSRu 2020 · MR1s
- 走線 內走線 (僅適用於電子變速)



VETOX ACE 幾何表

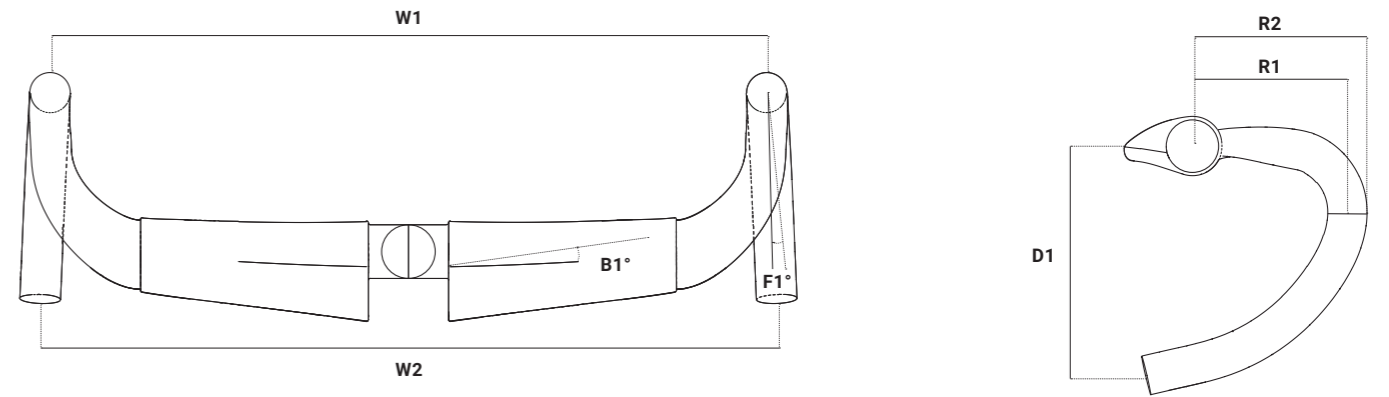

尺寸 (mm)	38	40	42	44
W1 Hood-to-hood	380	400	420	440
W2 Drop-to-drop	392	412	432	452
R1 Reach	85	85	85	85
R2 Reach	97	97	97	97
D1 Drop	138	138	138	138
F1 Drop flare	2	2	2	2
B1 Backsweep	0	0	0	0



AEROMAX



關於 AEROMAX

類型	空力把
材質	碳纖維
尺寸	38 · 40 · 42 · 44
重量	230±10g
相容型號	MR1s
走線	外走線



AEROMAX 幾何表

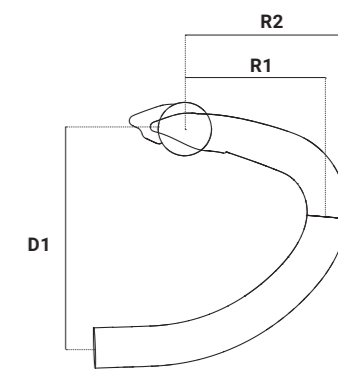
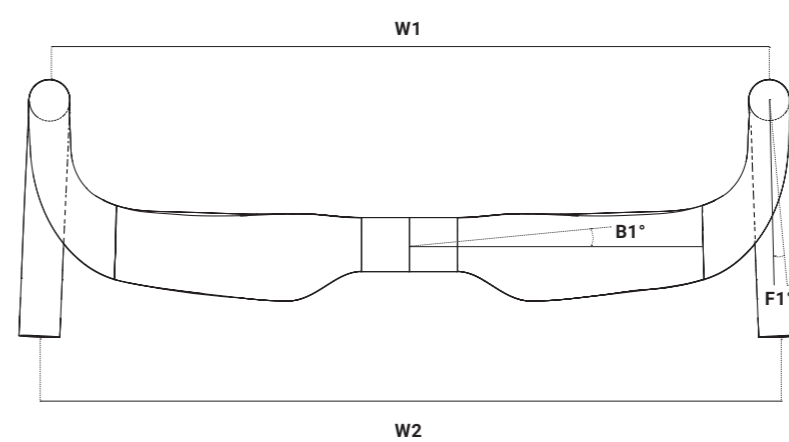

尺寸 (mm)	38	40	42	44
W1 Hood-to-hood	380	400	420	440
W2 Drop-to-drop	392	412	432	452
R1 Reach	85	85	85	85
R2 Reach	96	96	96	96
D1 Drop	130	130	130	130
F1 Drop flare	2	2	2	2
B1 Backsweep	0	0	0	0